

RAVEN[®] ANTERIOR

Anterior Lumbar Plate System





choicespine.com

Table of Contents

Introduction	4
Systems Features	4
Screw Selection and Preparation Options.....	6
Plate-Only Technique	7
Step 1a—Plate Placement	7
Step 1b—Screw Hole Preparation	7
Step 1c—Screw Insertion.....	8
Step 1d—Cam Lock Mechanism.....	9
Combination Plate and Interbody Technique.....	10
Step 2a—Combo Inserter Instructions	10
Step 2b—Load the Coupler onto the Combo Inserter	10
Step 2c—Attach to Offset Tamp	10
Step 2d—Load the Cage/Plate onto the Combo Inserter.....	11
Step 2e—Insert Cage into Disc Space.....	11
Step 2f—Remove Combo Inserter leaving Coupler	11
Step 2g—Screw Preparation	12
Step 2h—Final Lock and Remove Coupler.....	12
Implant Removal.....	12
Instrument Tray	13
Implant Tray.....	14

RAVEN[®] ANTERIOR

Anterior Lumbar Plate System



Introduction

The ChoiceSpine Raven® Anterior Lumbar Plate System has comprehensive implants and instruments designed to improve the efficiency of anterior lumbar spine fusion. In addition, Raven A features an integrated cam locking mechanism for final locking with streamlined instrumentation. The Raven Anterior Plate provides accessible fixation at L5-S1 due to divergent screw angulation through the cortical rims of the superior and inferior vertebral bodies. Combining Raven A with an interbody like ChoiceSpine's Harrier® SA may reduce surgical steps.

System Features

- Four-Screw Anterior Plate
- Anterior Cortical Rim Fixation
- Variable Screw Angulation
- Simple Visual and Tactile Cam-Locking Mechanism for final locking
- Plate Heights: 15mm – 24mm
- Screw Lengths: 20mm – 35mm in 5mm increments
- Screw Diameters: \varnothing 5.0mm & \varnothing 5.5mm

Exposure and Graft/Interbody Trialing

The patient is placed in the supine position, then the operative site is prepared and draped in the usual fashion. Standard techniques for dissection is utilized to expose the targeted fusion level in the lumbar spine. Fluoroscopy is used to confirm the appropriate disc level has been exposed. A thorough discectomy is performed and the cartilaginous endplates are removed at the operative level. The size of the disc space is measured with sequential trials until the desired fit is achieved and the matching graft or interbody size is selected to restore the normal disc space height.



After exposure, disc preparation, and trialing has been completed, the Raven Anterior Plate may be implanted in one of two ways:

1. A plate-only technique, after the lumbar interbody has been placed.
2. A combined plate/interbody technique, with an appropriate ChoiceSpine Harrier® SA lumbar interbody by way of instrumentation that is provided.

Raven® Anterior Plate Offerings		
Plate Size (mm)	Screw-to-Screw Length "A" (mm)	Overall Length "B" (mm)
15	15	26
17	17	28
18.5	18.5	29.5
20	20	31
22	22	33
24	24	35

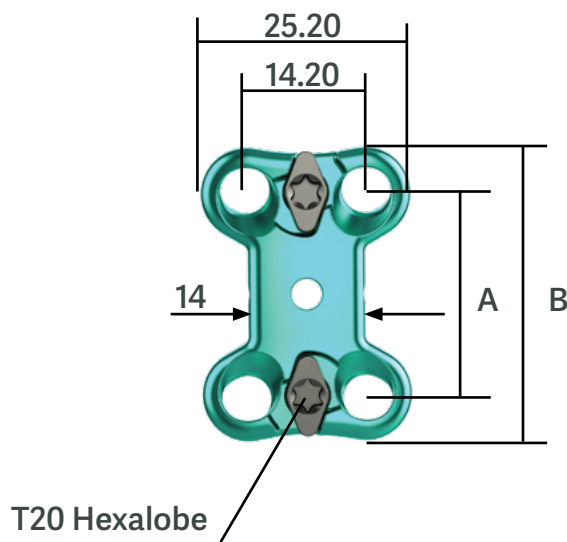

The Raven Anterior Lumbar Plates that correspond with the ChoiceSpine Harrier-SA interbodies are available in screw-to-screw lengths ranging from 17mm to 24mm. The suggested pairing is included in the table below.

Screw Offerings		
Diameter	Length (mm)	
Ø5.0 Self-Tapping Screw	20, 25, 30, 35	
Ø5.0 Self-Tapping Screw		

ALIF Pairing Sizes	
Harrier® SA ALIF Interbody Height (mm)	Raven® ALIF Plate Screw-to-Screw Length (mm)
12	17
13.5	18.5
15	20
17	22
19	24

NOTE: The pairing in the table above depicts the closest possible screw insertion point to the anterior corners of the lumbar interbody/vertebral endplates without interference between the screws and interbody. A larger plate can be selected for a given interbody, if desired.

WARNING: Do not attempt to bend the Raven® Anterior Plates. It is designed such that the screw holes will rest near the anterior corners of the interbody and vertebral endplates. Therefore, contouring is not necessary. Bending the plate could cause unknown damage to the plate and possibly render it unusable.

Screw Selection and Preparation Options

The Raven Anterior Lumbar Plate System has been designed with simplicity in mind and allows for direct screw placement after plate insertion. The system includes Ø5.0mm and Ø5.5mm variable angle screws in lengths from 20mm to 35mm by 5mm increments.

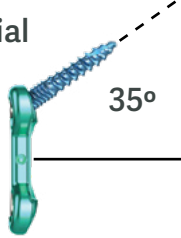
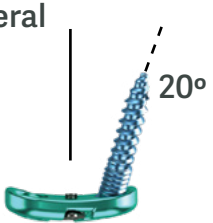
Angulation Range			
Neutral Screw Axis: 25° Cranial/Caudal and 10° Lateral		Maximum Screw Angles Shown	
Ø5.0 Screw	10° Cone Around Neutral Screw Axis	Cranial  35°	Lateral  20°
Ø5.5 Screw	5° Cone Around Neutral Screw Axis		

If pre-drilling is preferred, two methods are provided to correspond with the desired technique for plate implantation:

- 1) Using the Combination Awl/Drill with incorporated Guide Sleeve or
- 2) Using the Drill Guide and Drill provided. These methods are described with each respective plate insertion technique.

NOTE: Stay within the limits of screw angulation when drilling for and inserting screws to ensure the screw blocking mechanism engages properly.

Plate-Only Technique

Step 1a: Plate Placement

After selecting a plate, place it onto the lumbar spine using the **Anterior Inserter (Y070-1000)**. The Anterior Plate can be attached to the Anterior Inserter while seated in the Anterior Plate Caddy. Align Anterior Inserter and Anterior Plate mating features. Push Anterior Inserter outer sleeve forward until a hard stop is reached. Keep downward pressure on the sleeve and rotate sleeve in a clockwise position until the Anterior Inserter is attached to the desired fit. Center the Anterior Plate over the lumbar interbody in the disc space. Proper placement can be verified visually by confirming that the screw holes are not obstructed by the interbody.

Step 1b: Screw Hole Preparation

Use the Anterior Inserter and selected screw preparation instrument, **Combination Awl/Drill (Y070-1006)** /Drill 3.0mm (Y070-1005), and/or **Awl (Y070-1007)**, to prepare screw holes. Hold the plate in the desired position over the interbody. Attach the $\frac{1}{4}$ " **Square Quick Connect Handle (M070-0003)** to the selected screw preparation instrument. Insert the instrument into a screw pocket in the Raven plate and gently apply pressure while rotating to penetrate the vertebral body. Repeat this step for preparation of the second screw hole. The illustrations below demonstrate use of the Anterior Inserter and screw preparation instruments. The screw preparation instruments allow for $\text{Ø}3.0 \times 20\text{mm}$ of bone penetration.

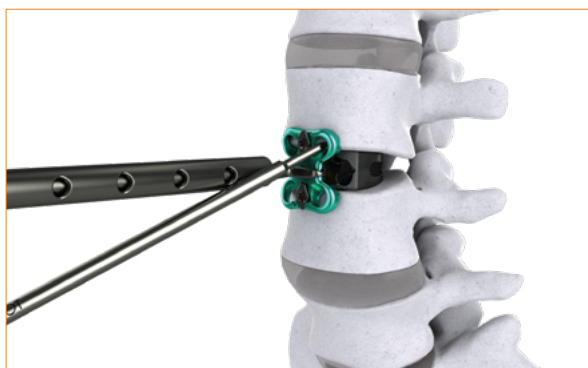

Screw Preparation with Awl (Y070-1007)



Screw Preparation with Combination Awl/Drill Instruments (Y070-1006)

NOTE: The Variable Angle Guide (Y070-1004) is available for use with the Awl and/or Drill. Marked bands on the proximal end of the instrument aligns with the proximal end of the guide to indicate penetration depth of instrument.



Awl (Y070-1007) with the Variable Guide (Y070-1004)



Guide Depth Markings on proximal end of Awl (Y070-1004)

Step 1c: Screw Insertion

Remove the selected screw preparation instrument from the surgical site prior to screw insertion. The Anterior Inserter may remain in place, if desired, to maintain plate location while starting screws. Select the appropriate diameter and length of screw and attach it to the Screwdriver (Y070-0043), as shown below. Advance the screw until it is fully seated in the plate. Repeat steps for placement of the second screw. Take care to stay within the limits of screw angulation so that the screw blocker can be rotated over a portion of the screw heads and engage the locking features on the face of the plate. Remove the Anterior Inserter by rotating the outer sleeve counterclockwise until the inserter releases from the implant. Placement of remaining two screws is accomplished after removing the inserter.

NOTE: The cranial and caudal pairs of screws must be inserted in the plate before engaging the screw blocker to cover the screw heads.



Screw Implantation

Step 1d: Cam Locking Mechanism

Engage the Cam Locking Mechanism after placement of all four screws. To engage, insert the Screwdriver into the T20 hexalobe at the center of the cam of the plate. Gently rotate the cam clockwise 90° until it has visual and tactile confirmation of locking. The cam does not require aggressive force to turn. Cam engagement is demonstrated in the illustrations below.



Cam Engagement

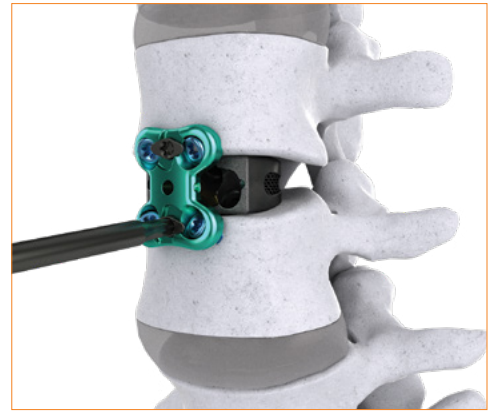

Unlocked Cam



Locked Cam

WARNING: Numerous rotations of the cam causes deformation of its locking feature. Do not repeatedly engage/disengage the cam to/from the locked position. The user should verify correct screw placement BEFORE engaging the cam. It should be noted that the cam is NOT required for securing the screws to the plate. It is a backup mechanism to prevent screws from backing out of the plate and potentially causing local tissue irritation if screws become loose. Do not attempt to over-rotate the cam once cam reaches its "locked" position.



Completed Construct

Combination Plate and Interbody Technique

The Raven® Anterior plate and Harrier® SA are designed to be implanted together to reduce surgical steps.

Step 2a. Combo Inserter Instructions

- Insert Draw Rod (Y070-0055) through the Combo Inserter (Y070-0046).
- Thread Draw Rod until flush with the Combo Inserter.

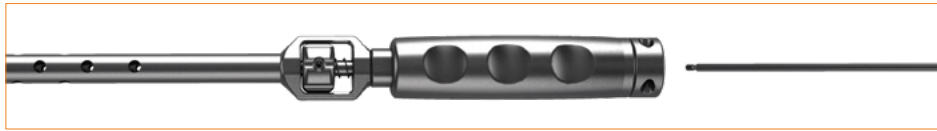

Step 2b. Load the Coupler onto the Combo Inserter

- Align inner shaft of Combo Inserter with Coupler (Y070-0047) in Raven Screw Caddy (Y090-4200).
- Rotate Draw Rod clockwise to engage the internal thread of the Coupler.
- Remove Combo Inserter and Coupler from Caddy.



Step 2c. Attach the Offset Tamp

- Select appropriate size Tamps: 0mm, 2mm or 4mm Offset (Y070-0048, Y070-0050, Y070-0052).
- Guide selected size Tamp over the distal end of the Coupler and snap onto Combo Inserter.



Step 2d. Load Cage/Plate onto Combo Inserter

- Load plate and cage pairing into Loading Block (Y070-1009).
- Align Tamp arms around plate waist and Coupler threads through central hole.
- Rotate thumbwheel clockwise until snug.
- Remove the connected implants from Loading Block.

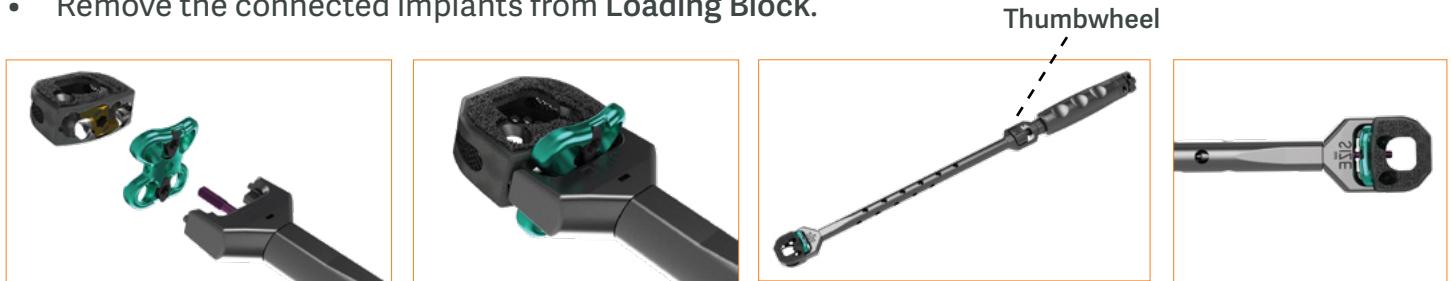

Step 2e: Insert Cage into Disc Space

The plate will rest against anterior face of the vertebral bodies. The Cage will counter sink into disc space during impaction.

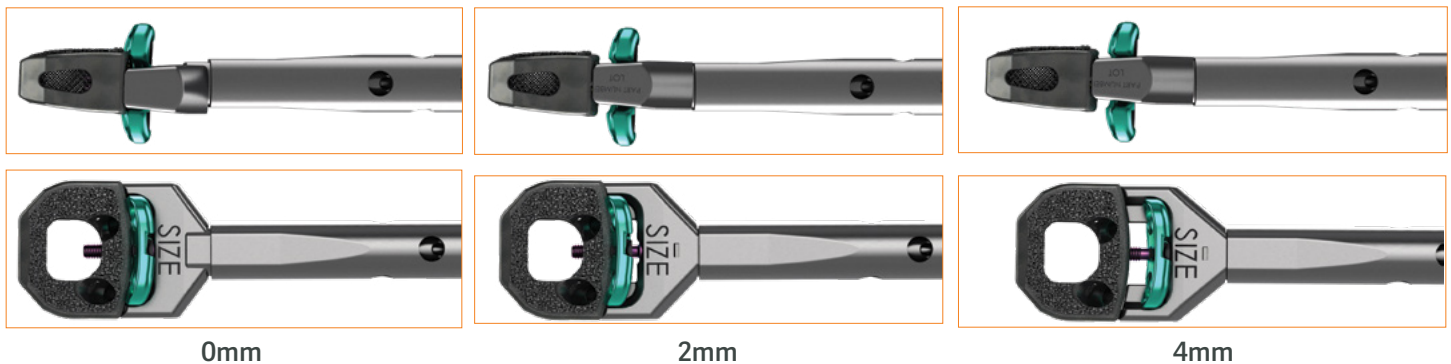

Step 2f. Remove Combo inserter leaving Coupler

- Rotate the Draw Rod a few times counterclockwise until Draw Rod can be pulled proximally to release the Combo Inserter from the Coupler.

CAUTION: Hold thumbwheel to prevent unthreading of Coupler.

- Remove the Combo Inserter leaving the cage, plate and coupler in the body.



Step 2g: Screw Preparation

Refer to the [Plate-Only Technique/Screw Hole Preparation](#) section above for screw preparation information. Preparation technique information for the [Combination Plate and Interbody Technique](#) is identical to the [Plate-Only Technique](#). The Screw preparation instruments can be used while the Anterior Plate/Cage Inserter is attached for two of the four plate screws. The Anterior Combo Inserter (Y070-0046) will have to be removed to prepare the remaining two screw holes.

Step 2h. Final Lock and Remove Coupler

- See [Plate-Only Technique/Cam Locking Mechanism](#) for cam locking mechanism.
- Reattach combo inserter to coupler by rotating the draw rod knob
- Rotate Thumbwheel counterclockwise to remove Coupler from Cage/Plate



Implant Removal

Use the Raven Screwdriver (Y070-0043) to rotate the cams to the unlocked position, fully exposing the screw heads for screwdriver access. Insert the Screwdriver into each screw head and reverse the screw from the vertebral body and plate. Attach the Anterior Plate Inserter or other grasping instrument to remove the plate from the surgical site.



Unlocking of cam

Removal of screw

Raven® Anterior Bottom Tray



- Ⓐ Ratcheting Quick Connect Axial Handle (M070-0003) x2
- Ⓑ Ratcheting Quick Connect Palm Handle (E070-0071)
- Ⓒ Anterior Plate/Screw Caddy (Y090-4200)
- Ⓓ Loading Block, Plate/Cage (Y070-1009)

NOTE: This is set-up for ALIF (Raven® A), the Anterior Plate/ Screw Caddy and Loading Block need to be ordered separately from the tray.

Notes:

For Instructions for Use please visit <https://choicespine-eifu.com/>



RAVEN[®] ANTERIOR

Anterior Lumbar Plate System

Spine the Right Way.[™]



400 Erin Drive, Knoxville, TN 37919 | O: 865.246.3333 | F: 865.246.3334 | choicespine.com